

HD26LS31

Quadruple Differential Line Drivers With 3 State Outputs

HITACHI

ADE-205-576 (Z)
1st. Edition
Dec. 2000

Description

The HD26LS31 features quadruple differential line drivers which satisfy the requirements of EIA standard RS-422A. This device is designed to provide differential signals with high current capability on bus lines. The circuit provides enable input to control all four drivers. The output circuit has active pull up and pull down and is capable of sinking or sourcing 40 mA.

Logic Diagram

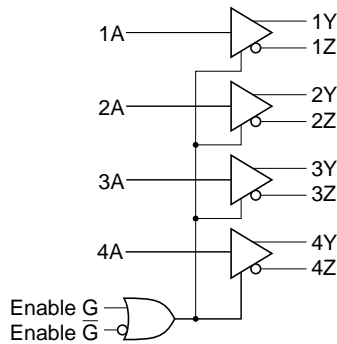

Pin Arrangement

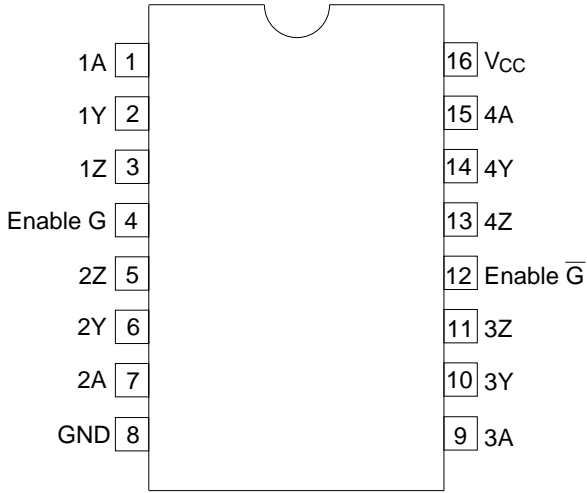

(Top view)

Function Table

Input A	Enables		Outputs	
	G	\bar{G}	Y	Z
H	H	X	H	L
L	H	X	L	H
H	X	L	H	L
L	X	L	L	H
X	L	H	Z	Z

H : High level

L : Low level

X : Irrelevant

Z : High impedance (Off)

Absolute Maximum Ratings

Item	Symbol	Ratings	Unit
Supply Voltage	V_{CC}	7.0	V
Input Voltage	V_{IN}	7.0	V
Output Voltage	V_{OUT}	5.5	V
Power Dissipation	P_T	1	W
Storage Temperature Range	T_{opr}	0 to +70	°C
Lead Temperature Range	T_{stg}	-65 to +150	°C

Note: 1. The absolute maximum ratings are values which must not individually be exceeded, and furthermore, no two of which may be realized at the same time.

Recommended Operating Conditions

Item	Symbol	Min	Typ	Max	Unit	Application Terminal
Supply Voltage	V_{CC}	4.75	5.0	5.25	V	VCC
Output Current	I_{OH}	—	—	-40	mA	All Output
Output Current	I_{OL}	—	—	40	mA	All Output
Operating Temperature	T_{opr}	0	25	70	—	—

Electrical Characteristics (Ta = 0 to +70°C)

Item	Symbol	Min	Typ*1	Max	Unit	Application Terminal	Conditions
Input Voltage	V_{IH}	2.0	—	—	V	All Inputs	
	V_{IL}	—	—	0.8			
Input Clamp Voltage	V_{IK}	—	—	-1.5			$V_{CC} = 4.75\text{ V}$, $I_I = -18\text{ mA}$
Output Voltage	V_{OH}	2.5	—	—		All Outputs	$V_{CC} = 4.75\text{ V}$ $I_{OH} = -20\text{ mA}$ $I_{OH} = -40\text{ mA}$ $I_{OL} = 40\text{ mA}$
	V_{OH}	—	—	2.4			
	V_{OL}	—	—	0.5			
Output Current	I_{OZL}	—	—	-20	mA		$V_{CC} = 5.25\text{ V}$ $V_O = 0.5\text{ V}$
	I_{OZH}	—	—	20			$V_{CC} = 5.25\text{ V}$ $V_O = 2.5\text{ V}$
Input Current	I_I	—	—	0.1	mA	All Inputs	$V_{CC} = 5.25\text{ V}$ $V_I = 7\text{ V}$
	I_{IH}	—	—	20			$V_I = 2.7\text{ V}$
	I_{IL}	—	—	-0.36			$V_I = 0.4\text{ V}$
Short Circuit Output Current	I_{OS}^{*2}	-30	—	-150		All Outputs	$V_{CC} = 5.25\text{ V}$
Supply Current	I_{CC}	—	32	80		V_{CC}	$V_{CC} = 5.25\text{ V}$

Notes: 1. All typical values are at $V_{CC} = 5\text{ V}$, $T_a = 25^\circ\text{C}$

2. Not more than one output should be shorted at a time and duration of the short circuit should not exceed one second.

Switching Characteristics ($V_{CC} = 5\text{ V}$, $T_a = 25^\circ\text{C}$)

Item	Symbol	Min	Typ	Max	Unit	Application terminal	Test circuit	Conditions
Propagation Delay Time	t_{PLH}	—	14	20	ns	All Outputs	1	$C_L = 30\text{ pF}$
	t_{PHL}	—	14	20				
Output Enable Time	t_{ZH}	—	25	40	ns		2	$C_L = 30\text{ pF}$, $R_L = 75\ \Omega$
	t_{ZL}	—	37	45			3	$C_L = 30\text{ pF}$, $R_L = 180\ \Omega$
Output Disable Time	t_{HZ}	—	21	30	ns		2	$C_L = 10\text{ pF}$
	t_{LZ}	—	23	35			3	$C_L = 10\text{ pF}$
Complementary Output To Output	Skew	—	1	6	ns		1	$C_L = 30\text{ pF}$

Test Circuit 1

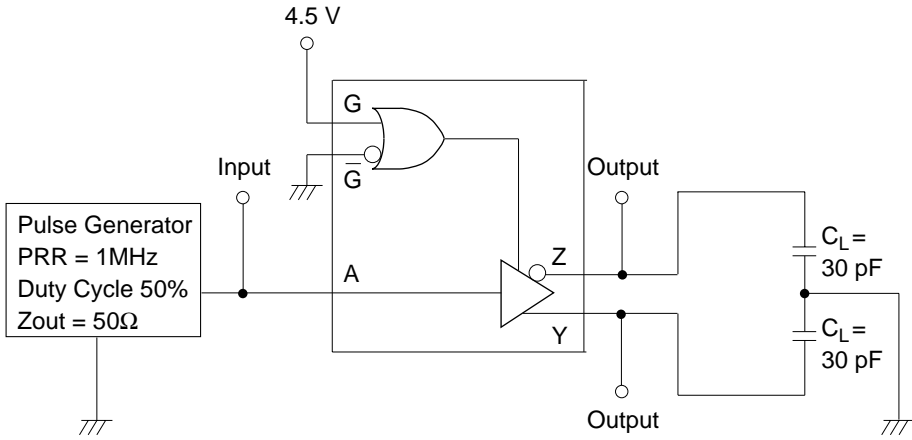

Note: 1. C_L includes probe and jig capacitance.

Waveforms

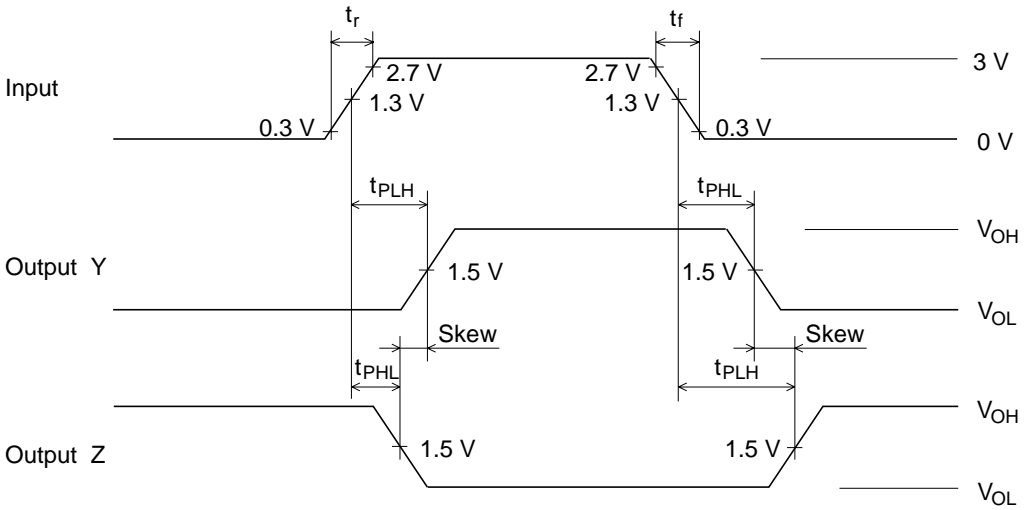

Test Circuit 2

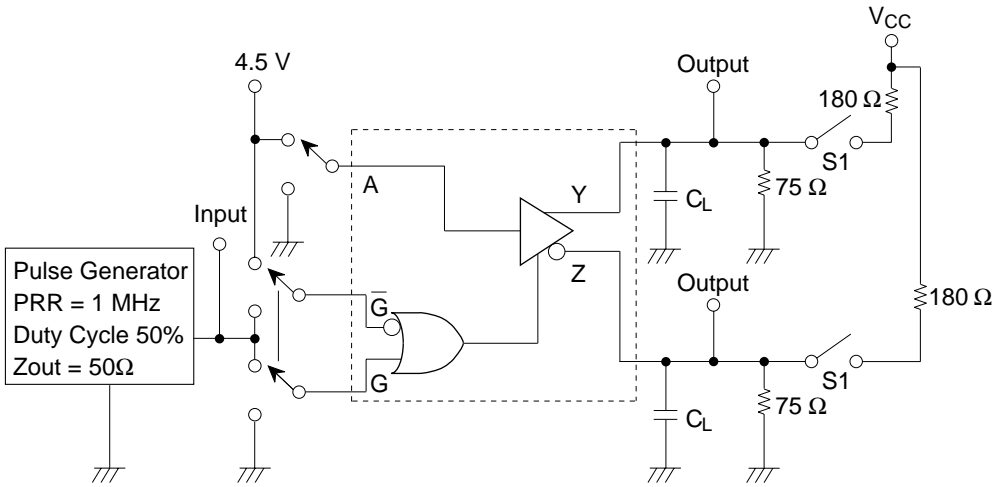

Note: 1. C_L includes probe and jig capacitance.

Waveforms

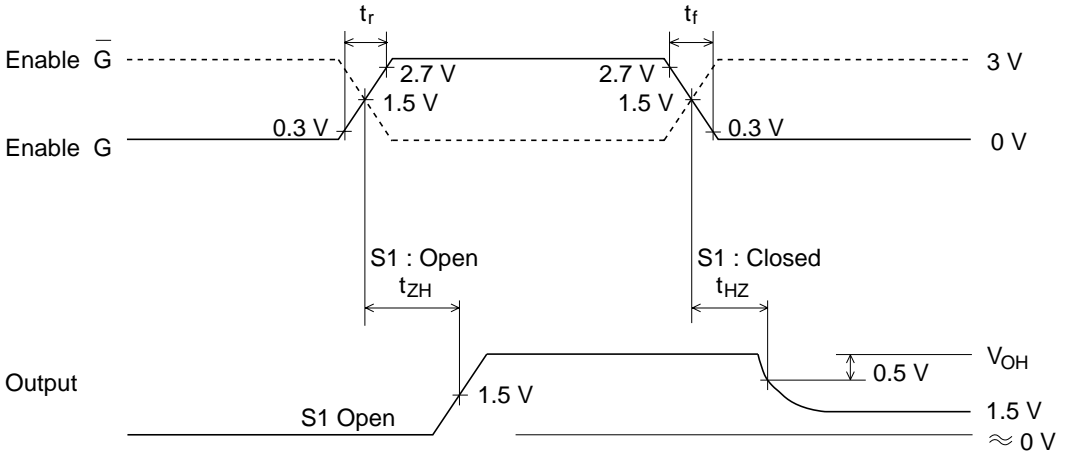

Test Circuit 3

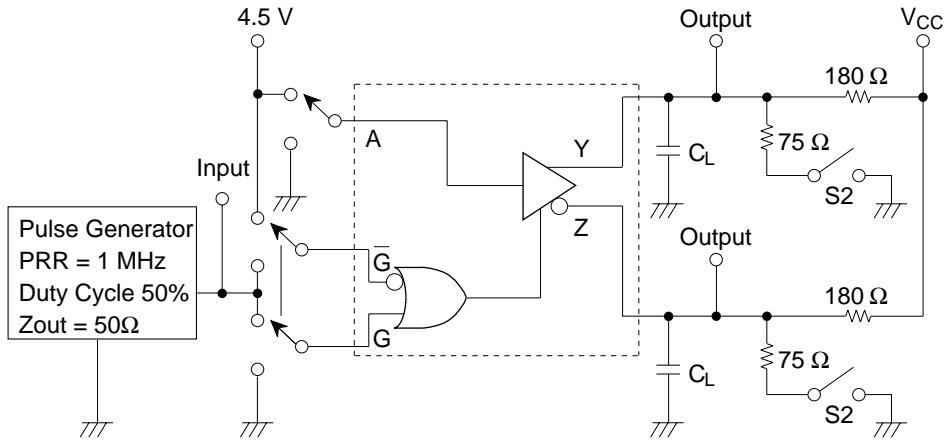

Note: 1. C_L includes probe and jig capacitance.

Waveforms

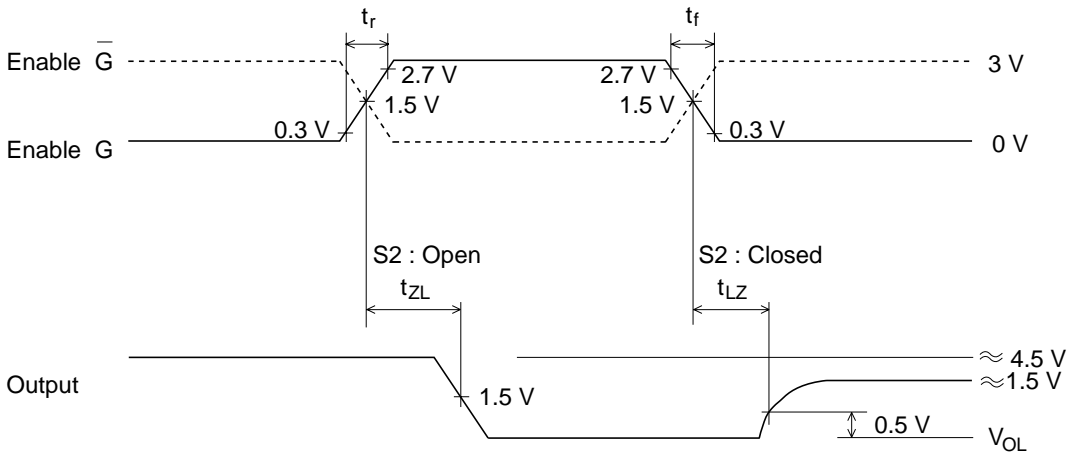

HD26LS31 Line Driver Applications

The HD26LS31 is a line driver that meets the EIA RS-422A conditions, and has been designed to supply a high current for differential signals to a bus line. Its features are listed below.

- Operates on a single 5 V power supply.
- High output impedance when power is off
- Three-state output
- On-chip current limiter circuit
- Sink current and source current both 40 mA

A block diagram is shown in figure 1. The enable function is common to all four drivers, and either active-high or active-low can be selected.

The output section consists of two output stages (the Y side and Z side), each of which has the same sink current and source current capacity.

Input is TTL compatible, and an output current limiter circuit is built into the output stage as shown in figure 2.

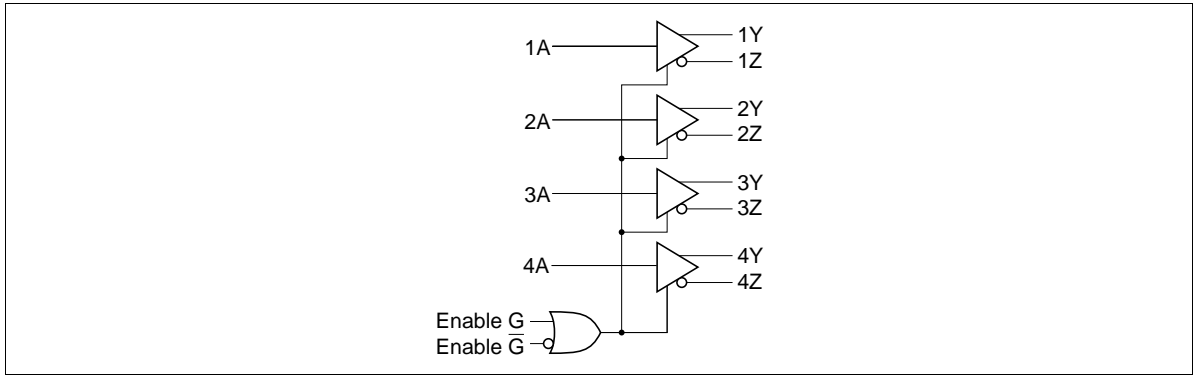

Figure 1 HD26LS31 Block Diagram

The output current limiter circuit consists of transistor Q_1 and resistance R_1 , and operates when the voltage drop on both sides of R_1 reaches approximately 0.7 V. At this time the current, i , is as follows:

$$i = 0.7 \text{ (V)} / 9 \text{ (\Omega)} \approx 78 \text{ (mA)}$$

When a current greater than this flows, Q_1 is turned on, the Q_2 base current flows to the output side, and the flow of an excessively large output current is prevented.

However, since this type of current limiter circuit has the characteristics shown in figure 3, the output stage power dissipation is large.

Therefore, when the output is shorted, this should be limited to a maximum of one second for one pin only.

The I_{OL} vs. V_{OL} characteristic for low-level output is shown in figure 4.

An example of termination resistance connection when the HD26LS31 is used as a balanced differential type driver is shown.

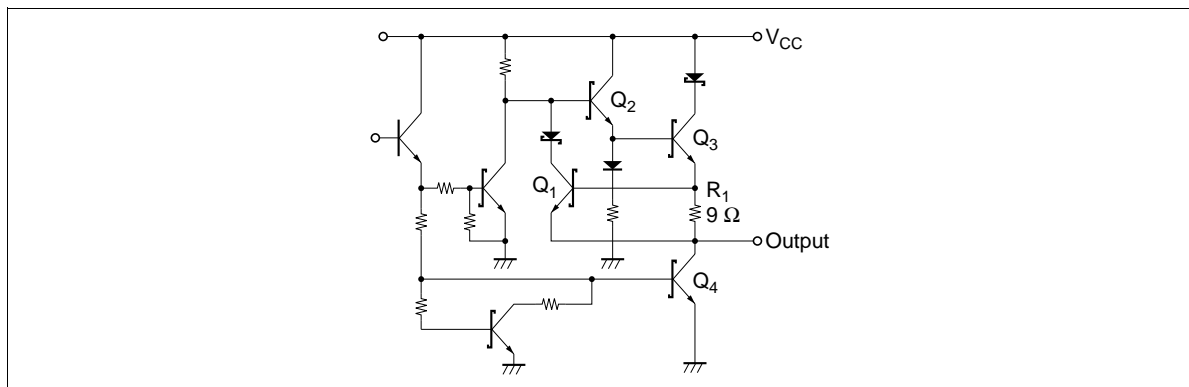

Figure 2 Output Stage Circuit Configuration

When termination resistance R_T is connected between the two transmission lines, as shown in figure 7 the current path situation is that current I_{OH} on the side outputting a high level (in this case, the Y output) flows to the side outputting a low level (in this case, the Z output) via R_T , with the result that the low level rise is large.

If termination resistance R_T is dropped to GND on both transmit lines, as shown in figure 5 the current path situation is that the current that flows into the side outputting a low level (in this case, the Z output) is only the input bias current from the receiver. As this input bias current is small compared with the signal current, it has almost no effect on the differential input signal at the receiver end.

Figure 6 shows the output voltage characteristics when termination resistance R_T is varied.

Also, when used in a party line system, etc., the low level rises further due to the receiver input bias current, so that it is probably advisable to drop the termination resistance to GND.

However, the fact that it is possible to make the value of R_T equal to the characteristic impedance of the transmission line offers the advantage of being able to hold the power dissipation on the side outputting a high level to a lower level than in the above case.

Consequently, the appropriate use must be decided according to the actual operating conditions (transmission line characteristics, transmission distance, whether a party line is used, etc.).

Figure 8 shows the output voltage characteristics when termination resistance R_T is varied.

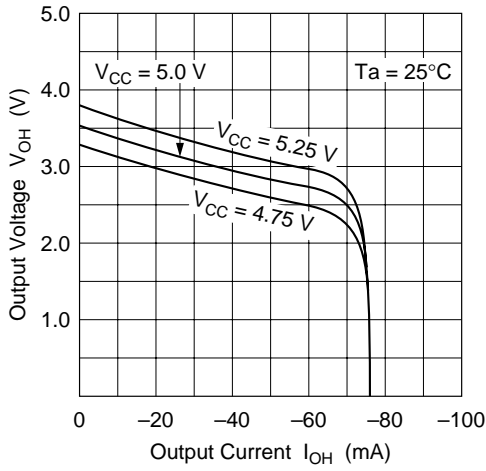

Figure 3 I_{OH} vs. V_{OH} Characteristics

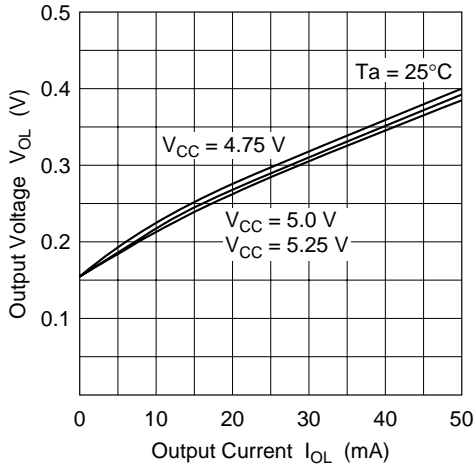

Figure 4 I_{OL} vs. V_{OL} Characteristics

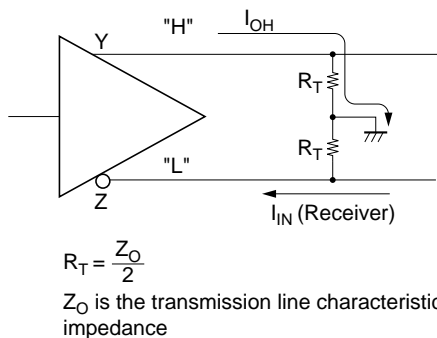

Figure 5 Example of Driver Use-1

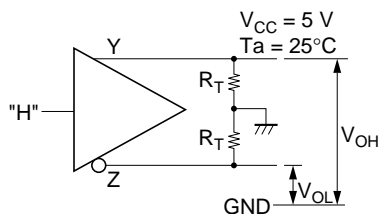
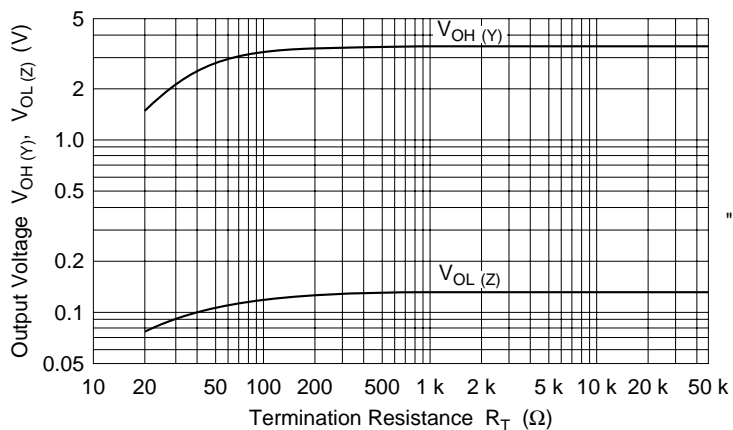

Figure 6 Termination Resistance vs. Output Voltage Characteristics

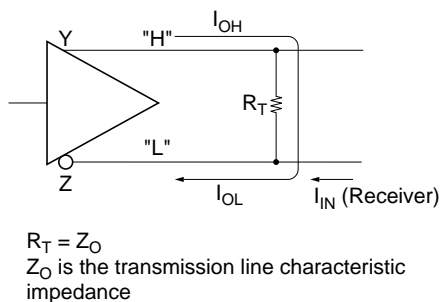

Figure 7 Example of Driver Use-2

A feature of termination implemented as shown in figure 9 is that power dissipation is low when the duty of the transmitted signal is high.

However, care is required, since if R_T is sufficiently small, when the output on the pulled-up side goes low, since the inverter transistor (Q_4 in figure 2) has no protection circuit, and so a large current will flow and the output low level will rise.

Figure 10 shows the output voltage characteristics when termination resistance R_T is varied.

With the method of using the driver described above, if termination resistance R_T becomes sufficiently small, the region within which the output current limiter circuit operates will be entered, as can be seen from the I_{OH} vs. V_{OH} characteristics shown in figure 3. In this region, the output stage power dissipation is large and the output voltage changes abruptly. A measure such as insertion of a capacitor in series with the termination resistance is therefore necessary. Consequently, when selecting the transmission line, the circuit termination resistance to be used requires careful consideration.

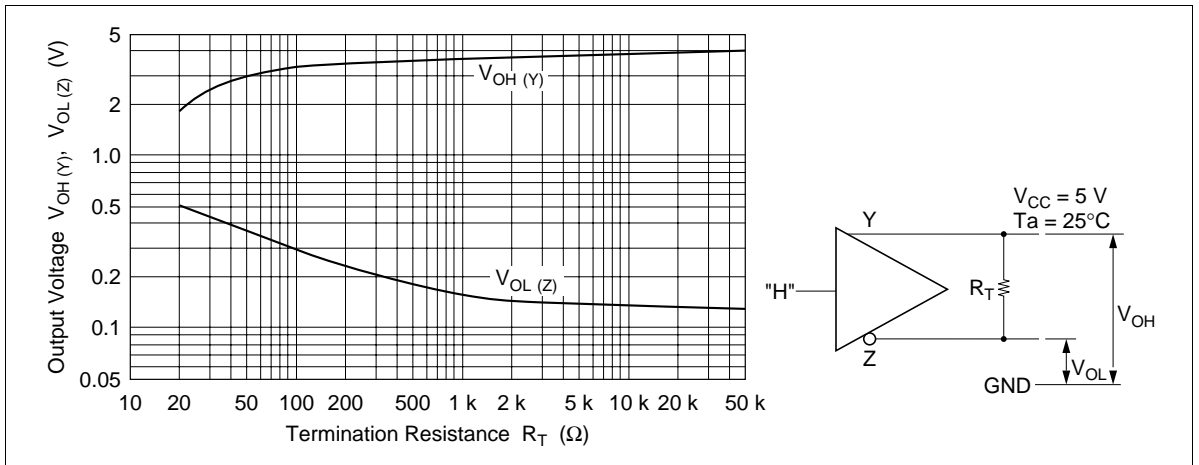

Figure 8 Termination Resistance vs. Output Voltage Characteristics

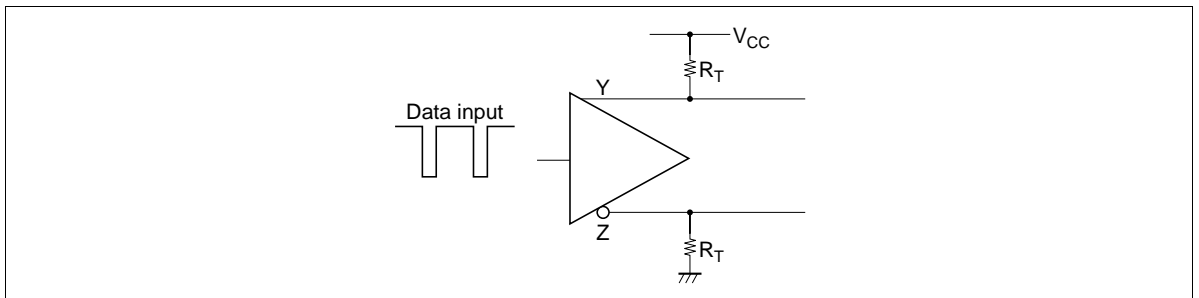

Figure 9 Example of Driver Use-3

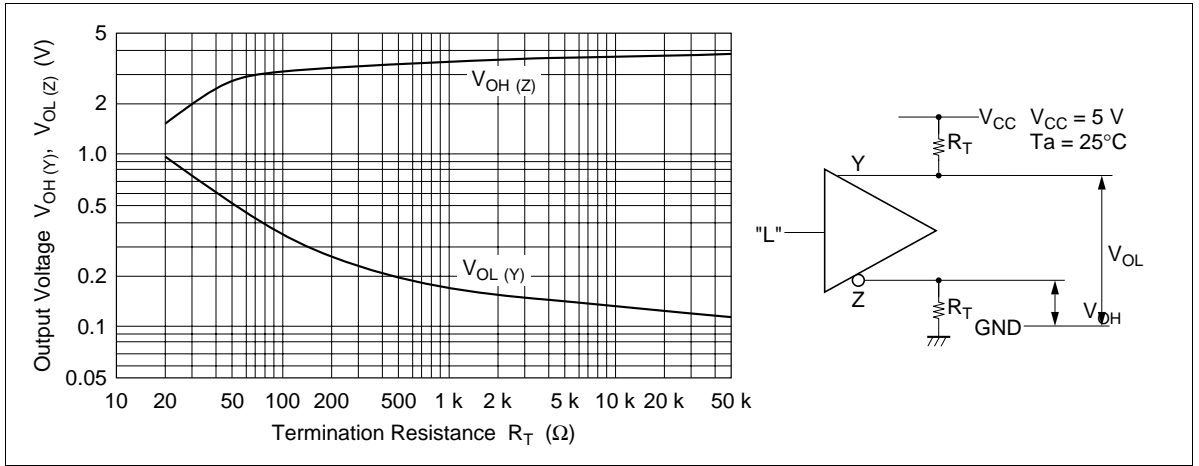
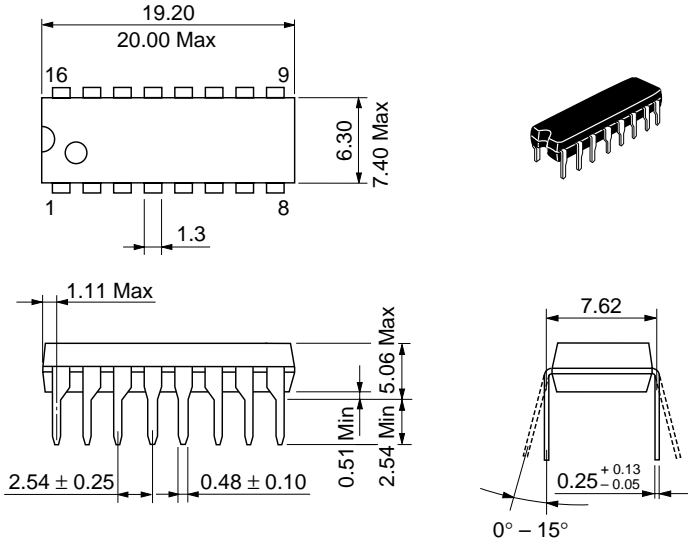

Figure 10 Termination Resistance vs. Output Voltage Characteristic

Package Dimensions

Unit: mm



Hitachi Code	DP-16
JEDEC	Conforms
EIAJ	Conforms
Mass (reference value)	1.07 g

Unit: mm

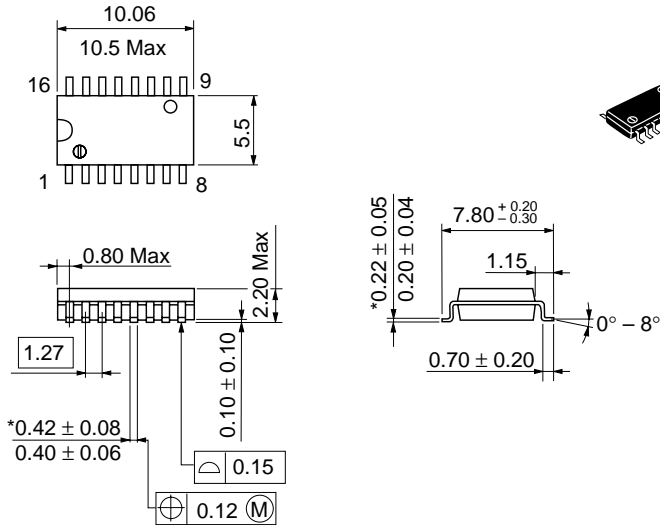

Hitachi Code	FP-16DA
JEDEC	—
EIAJ	Conforms
Mass (reference value)	0.24 g

*Dimension including the plating thickness
Base material dimension

Cautions

1. Hitachi neither warrants nor grants licenses of any rights of Hitachi's or any third party's patent, copyright, trademark, or other intellectual property rights for information contained in this document. Hitachi bears no responsibility for problems that may arise with third party's rights, including intellectual property rights, in connection with use of the information contained in this document.
2. Products and product specifications may be subject to change without notice. Confirm that you have received the latest product standards or specifications before final design, purchase or use.
3. Hitachi makes every attempt to ensure that its products are of high quality and reliability. However, contact Hitachi's sales office before using the product in an application that demands especially high quality and reliability or where its failure or malfunction may directly threaten human life or cause risk of bodily injury, such as aerospace, aeronautics, nuclear power, combustion control, transportation, traffic, safety equipment or medical equipment for life support.
4. Design your application so that the product is used within the ranges guaranteed by Hitachi particularly for maximum rating, operating supply voltage range, heat radiation characteristics, installation conditions and other characteristics. Hitachi bears no responsibility for failure or damage when used beyond the guaranteed ranges. Even within the guaranteed ranges, consider normally foreseeable failure rates or failure modes in semiconductor devices and employ systemic measures such as fail-safes, so that the equipment incorporating Hitachi product does not cause bodily injury, fire or other consequential damage due to operation of the Hitachi product.
5. This product is not designed to be radiation resistant.
6. No one is permitted to reproduce or duplicate, in any form, the whole or part of this document without written approval from Hitachi.
7. Contact Hitachi's sales office for any questions regarding this document or Hitachi semiconductor products.

HITACHI

Hitachi, Ltd.

Semiconductor & Integrated Circuits.
Nippon Bldg., 2-6-2, Ohte-machi, Chiyoda-ku, Tokyo 100-0004, Japan
Tel: Tokyo (03) 3270-2111 Fax: (03) 3270-5109

URL	NorthAmerica	: http://semiconductor.hitachi.com/
	Europe	: http://www.hitachi-eu.com/hel/ecg
	Asia	: http://sicapac.hitachi-asia.com
	Japan	: http://www.hitachi.co.jp/Sicd/indx.htm

For further information write to:

Hitachi Semiconductor
(America) Inc.
179 East Tasman Drive,
San Jose, CA 95134
Tel: <1> (408) 433-1990
Fax: <1> (408) 433-0223

Hitachi Europe GmbH
Electronic Components Group
Dornacher StraÙe 3
D-85622 Feldkirchen, Munich
Germany
Tel: <49> (89) 9 9180-0
Fax: <49> (89) 9 29 30 00

Hitachi Europe Ltd.
Electronic Components Group.
Whitebrook Park
Lower Cookham Road
Maidenhead
Berkshire SL6 8YA, United Kingdom
Tel: <44> (1628) 585000
Fax: <44> (1628) 585160

Hitachi Asia Ltd.
Hitachi Tower
16 Collyer Quay #20-00,
Singapore 049318
Tel: <65>-538-6533/538-8577
Fax: <65>-538-6933/538-3877
URL: <http://www.hitachi.com.sg>

Hitachi Asia Ltd.
(Taipei Branch Office)
4/F, No. 167, Tun Hwa North Road,
Hung-Kuo Building,
Taipei (105), Taiwan
Tel: <886>-(2)-2718-3666
Fax: <886>-(2)-2718-8180
Telex: 23222 HAS-TP
URL: <http://www.hitachi.com.tw>

Hitachi Asia (Hong Kong) Ltd.
Group III (Electronic Components)
7/F., North Tower,
World Finance Centre,
Harbour City, Canton Road
Tsim Sha Tsui, Kowloon,
Hong Kong
Tel: <852>-(2)-735-9218
Fax: <852>-(2)-730-0281
URL: <http://www.hitachi.com.hk>

Copyright © Hitachi, Ltd., 2000. All rights reserved. Printed in Japan.
Colophon 2.0

HITACHI